



Self-loading concrete mixer **Premier 3**, due to its tubular structure, combines flexibility and robustness.

Its features make it the actual reference in its sector, mainly because of:

- The speed and quality of mixture
- The big capacity of the loading shovel
- The big capacity of the tanks
 - Water
 - Fuel
 - Hydraulic oil
- Rops-Fops cabin, placed in the loading area for a better visibility of the operator.
- It avoids useless stops optimizing duty time and thus the efficiency.
- Engine accomplishing TIER III standard.
- 270° Rotation of drum and hydraulic lifting of it for pouring aid.
- Handling and controls inside the cabin and by the drum



Fron axle steering



Both axles steering



Crab steering

Among other options, we offer **electronic weighing system with printer.**

Also optinals:

- **Closed cabin**
- **Elevation of drum for Support on discharge**
- **High-pressure washing**

PREMIER - 3

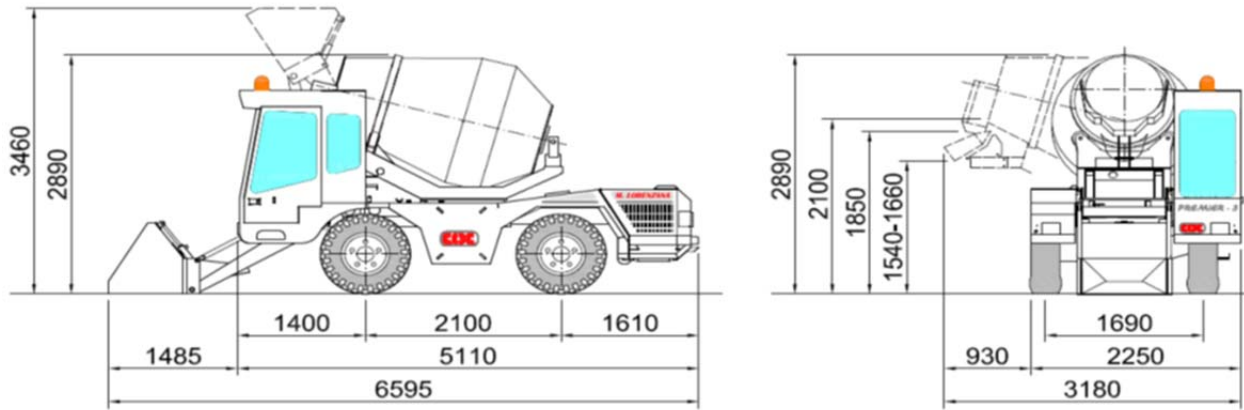

SMALL DIMENSIONS, BIG FEATURES

The unit is made for working under the worst conditions with the best and most advanced features in technology and safety.

EASY TO TRANSPORT

In this global world, forwarding equipment in a fast and safe way has become a need an obligatory feature. **Premier 3** has been designed for shipping two units in one only container, which can be delivered anywhere in the world.



Our "Premier" equipment is working in such different places as Angola, México, Dominican Republic, Russia, Brazil, Italy ... No need of more introductions; It is the answer to your requirements in civil Works with no doubt.

BRAND		C.O.C.
MODEL		PREMIER-3
OUTPUT CAPACITY		2.5 m ³
DRUM CAPACITY		3,300 Lit
MOTOR	BRAND	PERKINS
	MODEL	1104D-44T
	COOLING	AIR - OIL
	POWER	80 cv AT 2,200 R.P.M.
TRANSMISSION	TYPE	HYDROSTATIC
	GEARS	2 GEARS FORWARD AND REVERSE
AXLES		MONOBLOCK
AXLES CAPACITY		6,500 KGS
DRIVE		ON 4 WHEELS
CABIN		FRONT, OPEN
		JOYSTICK
		ROP - FOPS
STEERING	TYPE	HYDRO-ASSISTED
	FRONT AXLE	YES
	CRAB STEERING	YES
	REAR AXLE	YES
HYDRAULIC CIRCUITS	SHIFT	HYDROSTATIC DA SYSTEM
	DRUM ROTATION	HYDROSTATIC ELECTRICAL REGULATION
	BRAKES	GEARS PUMP
	STEERING & SERVICE	GEARS PUMP
BRAKES		"SELF-CONTROL" DEVICE
	SERVICES	OIL BATHED INNER DISCS ON 4 WHEELS
	PARKING	OIL BATHED INNER DISCS ON REAR AXLE
DIMENSIONS		6,595 mm*2,930 mm*2,890 mm
DRUM		DOUBLE BLADE
DRUM MOVEMENT		270°
STEERING RADIOS	INNER	1,600 mm
	OUTER	4,550 mm
POURING CHUTE		SWIVELLING AND ADJUSTABLE
CYCLE		7 - 10 MIN
SPEED	WORKING	0 TO 8 KM/H
	SHIFTING	0 TO 20 KM/H ACCORDING TO SPANISH RULES
MAXIMUM SLOPE		30%
ELECTRICAL SYSTEM		12 V BATTERY
POURING		270°
POURING HEIGHT		1,800 mm - 2,100 mm
TYRES		12.5 / 18 MPT02
WEIGHT		6,500 Kg
HYDRAULIC OIL TANK		125 Lit
WATER TANK		665 Lit
FUEL TANK		105 Lit
SHOVEL CAPACITY		550 Lit

Due to the constant process of improvement at factory, all data are subject to modification without prior notice, being merely illustrative all data in this catalogue.

MADRID: Ctra de Valencia, Km 19,200. 28524 RIVAS VACIAMADRID (MADRID). FAX: +34916701005. e-mail:madrid@mlorenzana.com

LEÓN: Pol. Ind. Villacedré. 24009 VILLACEDRÉ (LEÓN). FAX: +34987849036. e-mail:leon@mlorenzana.com

www.mlorenzana.com +34 902 151 236



PREMIER - 3



REF CAT: 00.AU.P3.13.EN.02



PREMIER - 3

