



SPRAYCON-CH14

General Features

Length	7529 mm
Width	1600 mm
High	2000 mm
Ground clearance	320 mm
Axle distance	3285 mm
Maximum slope in running order	40%
Maximum inclination in running order	20%
Inner turning radius	3400 mm
External turning radius	6000 mm
Weight	9300 Kg
Max. outreach Horizontal arm at the tip.	4600 mm
Max. outreach Vertical arm at tip	5700 mm
Max. vertical gunite range	6900 mm

Diesel engine

Brand	Caterpillar
Model	C 4.4 ACERT
Power	106 kW (140 CV)
Emissions	TIER 3

Diesel engine

Brand	Caterpillar
Model	C3.6
Power	100 kW (134 CV)
Emissions	Stage V

Transmission

Type	Powershift
Brand	JCB
Speeds	4
Drive	4 WD
Theoretical maximum speeds:	
1st Speed	4 Km/h
2nd Speed	8 Km/h
3rd Speed	14 Km/h
4th speed	20 Km/h
Theoretical maximum reverse speeds:	
1st Speed	4 Km/h
2nd Speed	8 Km/h
3rd Speed	14 Km/h
4th speed	20 Km/h

Steering

Type	Hydro-assisted
Actuation	40° joint
Steering cylinders	2
Central Oscillation	- 10° +10°

Brakes

Brakes Service (Oil bath)	Multidisc
Actuation	4 wheels
Parking (oil bath)	Negative
Actuation	Converter

Tank Capacity

Diesel Tank	270 Lt
Hydraulic Tank	320 Lt
Water tank	100 Lt
Additive tank	200 Lt

Cabin

Manufactured according to	ROPS / FOPS
Type	Closed
Air conditioning	Cold / Heat
Driving position	Fixed
Driver's seat	With belt
Rear camera	Yes
Access door	1

Concrete pump

Type	Piston 2
Theoretical maximum flow rate	20 m ³ /h
Diameter of transport cylinder	125 mm
Pumping distance	300 m
Maximum pressure on concrete	80 bar
Maximum gunite	16 mm
Maximum pumping rate	32 mm
Hopper capacity	200 lt
Actuation	Electric

Non-binding information document. Values are theoretical values. Specifications subject to change without notice.

SCCH14-2025I

SPRAYCON-CH14

Water pump Washing

Maximum pressure	100 bar
Caudal	10,5 l/min

Working arm

Maximum horizontal working range	5800 mm
Maximum vertical working range	6900 mm
Deployment section	1800 mm
Number of axles	4
Vertical working angle	150°

Header

Rotation	360°
Tilt	+120° -120°
Nutacion	10°
Nozzle	DN 50

Cable reels

Actuation	Hydraulic
Cable length	50 mt
Cable section without compressor	16 mm ²

Remote control

Actuation	Cable / Radio
Cable length	5 m

Additive pump

Flow rate	30 - 700 lt/h
Maximum pressure	10 bar
Control	Synchronised
Regulation	Remote control

Other

Tyres	14 R 17,5
Catalyst	Si

OPTIONAL EQUIPMENT

Fire suppression

Dafo	Dust
Fogmaker	Water

Grease

Centralised	Automatic
-------------	-----------

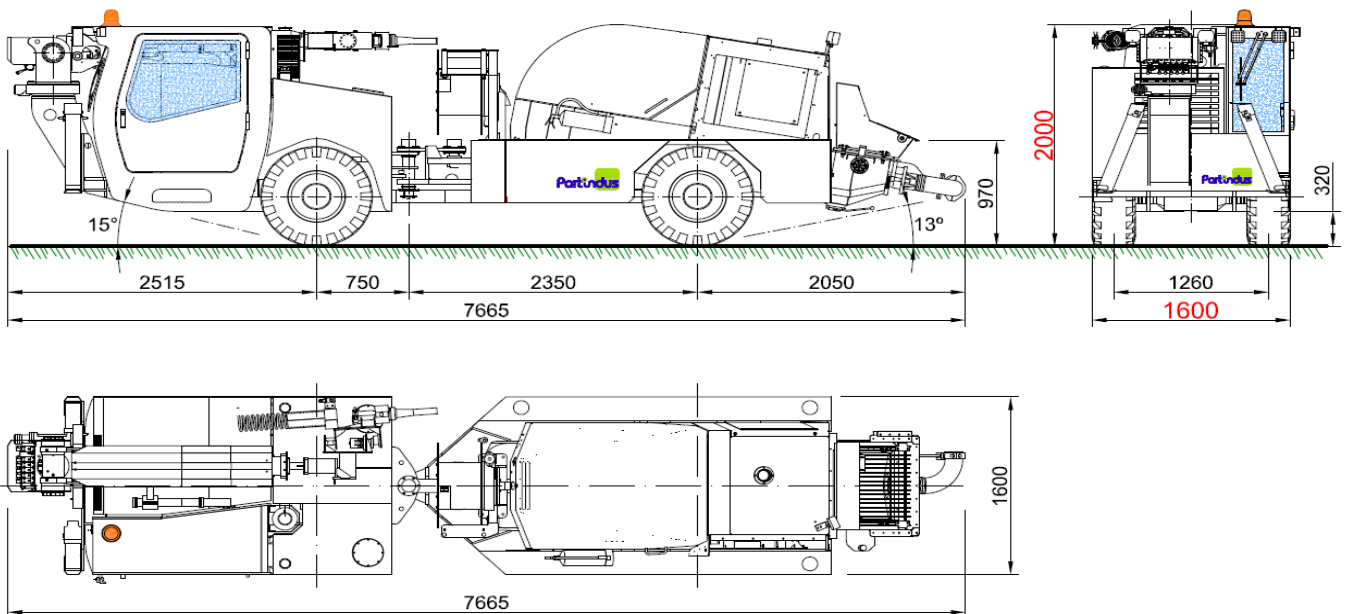

Non-binding information document. Values are theoretical values. Specifications subject to change without notice.