



WOMBAT

Características Generales

Length	3100 mm
Width	1100 mm
High	1500 mm
Ground clearance	265 mm
Axle distance	1500 mm
Maximum slope in running order	25%
Maximum inclination in running order	18%
Inner turning radius	1600 mm
External turning radius	2560 mm
Weight	2250 kg

Electric motor

Type	Permanent Magnet
Power (Continuous)	7 kW
Power (Peak)	20 kW

Power supply

Battery type	Lithium Ions
Gross capacity	10kWh
System voltage	48 V
Zero emissions at the point of use	

Transmisión

Tipo	Motor electrico
Acoplamiento	Caja transfer a ejes
Velocidad	Progresiva
Unica maxima en llano	12 Km/h

Direccion

Tipo	Hidroasistida
Accionamiento	Articulación 39º
Cilindros dirección	1
Oscilación central	12º + 12º

Frenos

De servicio	Dinamico/Hidrostatico
Accionamiento	2 ruedas
De estacionamiento	Negativo
Accionamiento	Dinamico/Hidrostatico

Working arm

Maximum horizontal working range	6000 mm
Maximum vertical working range	6660 mm
Deployment section	3100 mm
Number of axles	4
Vertical working angle	90º

Header

Rotation	360º
Tilt	+120º -120º
Nutacion	10º
Nozzle	DN 50

Remote control

Actuation	Cable / Radio
Cable length	5 m

Capacities

Hydraulic Tank Thermal Coating	28 lt
--------------------------------	-------

Charge

Integrated charger, allows direct connection to AC power	
Charging time, approx. 20% to 80%.	2h 40 min (230 V)

Other

Tyres	255/75 x 15,3 / 8pl
-------	---------------------

EQUIPOS OPCIONALES

Fire suppression

Dafo	Dust
Fogmaker	Water

Grease

Centralised	Automatic
-------------	-----------

Non-binding information document. The values indicated are theoretical values. Specifications subject to change without notice.

WOMBAT

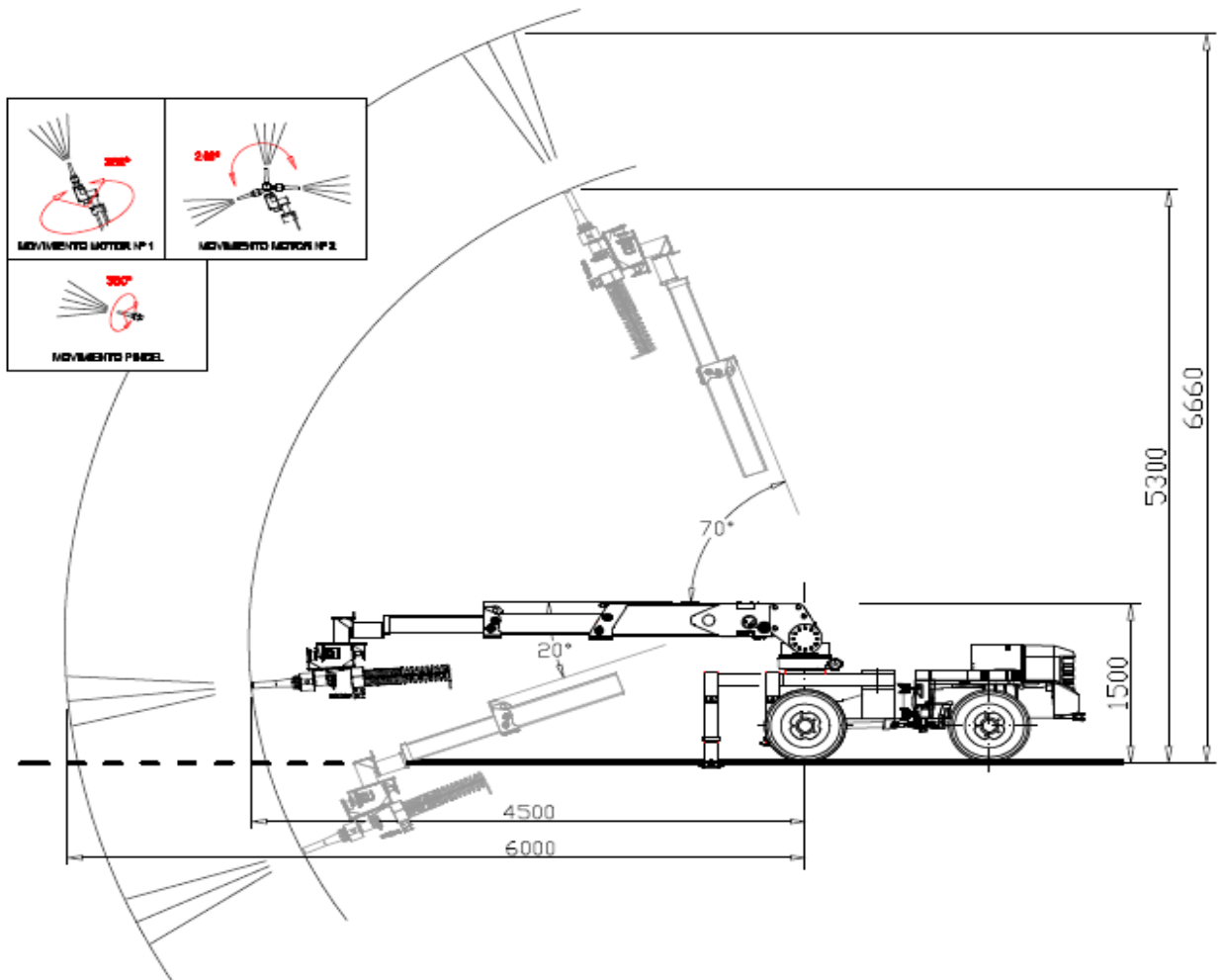
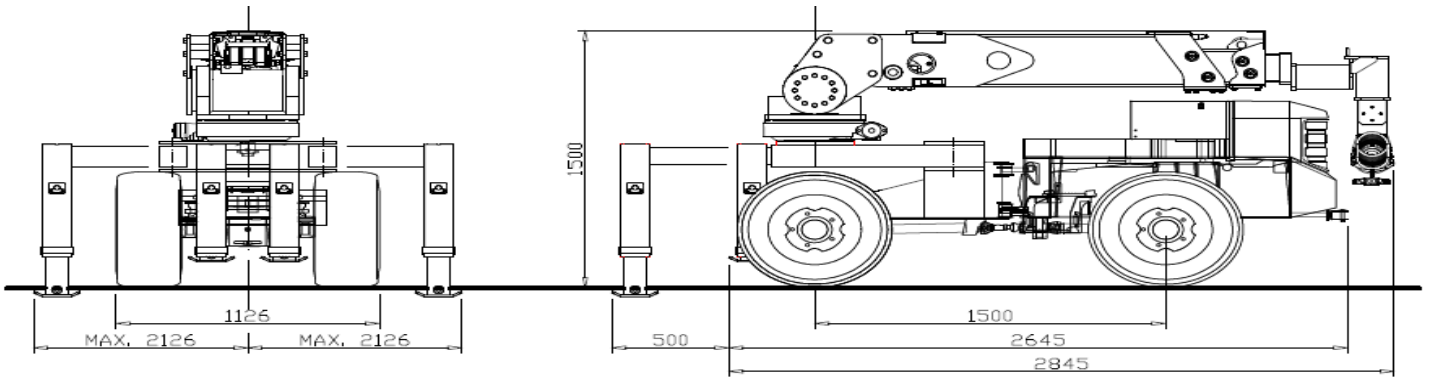

Non-binding information document. The values indicated are theoretical values. Specifications subject to change without notice.