



Dosing batching plants with big capacity and easy-to-use. Their versatility and their output make them the answer to your problems of aggregates supply in your site.

Together with **EUROSILOS** or **SILMATIC** and our self-loading mixers, they make a semi-portable plant for producing concrete at desired place and time.



Compact equipment, which due to its small dimensions can be installed in a short period of time on the available room.



Very Handy and versatile equipment for storing, weighing and discharging aggregates, which can select electronically the quantity by means of its 99 recipes, obtaining the accurate dose for, together with our silos and self-loading mixers, producing good quality concrete at site.



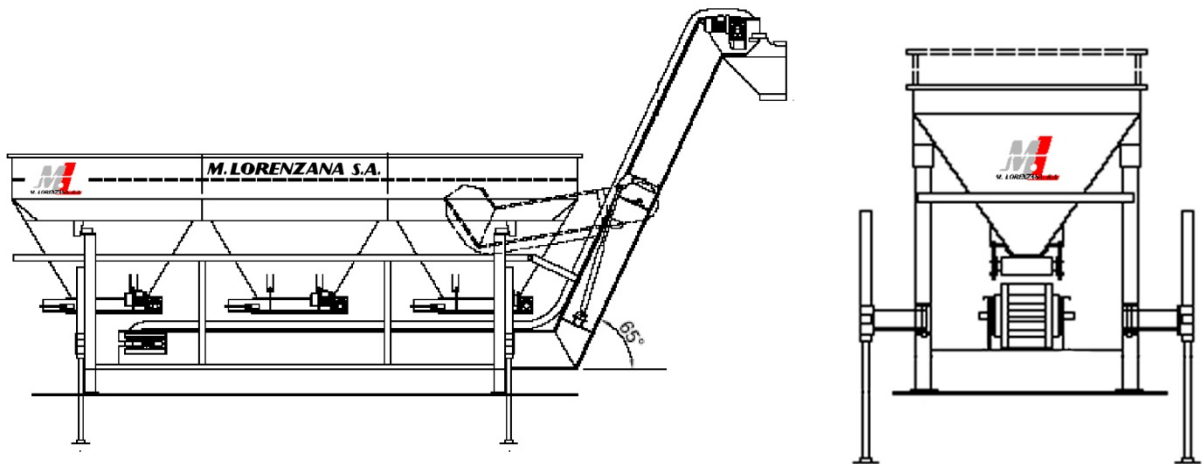

BATCHING PLANT



The equipment is provided with an electronic weighing system with digital panel and controlled by automatic programs, which allows us to discharge the pre-selected amount of the different aggregates loaded into each hopper, depending on the type of concrete we want to produce.



For transport and shipping, the top end of bucket conveyor belt can be swiveled down to the hoppers for reducing the height. Thanks to the four hydraulic stabilizers (optional) can be unloaded from the means of transport and can be installed on the suitable place with no need of a crane.

SPECIFICATIONS			
OUTPUT	60 m ³ /h	60 m ³ /h	60 m ³ /h
STORING HOPPERS	2	3	4
STORAGE CAPACITY PER HOPPER	8 m ³	8 m ³	8 m ³
LOADING WIDTH PER HOPPER	2.6 m	2.6 m	2.6 m
TRANSPORT LENGHT	7 m	9.6 m	12.5 m
TRANSPORT WIDTH	2.45 m	2.45 m	2.45 m
TRANSPORT HEIGHT	2.8 m	2.8 m	2.8 m
TOTAL WEIGHT	6,000 kg	8,000 kg	10,000 kg
THRE-PHASE POWER	380V - 50 Hz	380V - 50 Hz	380V - 50 Hz
ELEVATOR CONVEYOR BELT'S MOTOR	3.0 Kw. 1,400 r.p.m.		
EXTRACTOR CONVEYOR BELT'S MOTOR	2.2 Kw 1,400 r.p.m.		
HYDRAULIC SYSTEM MOTOR	2.2 Kw 1,400 r.p.m.		
VIBRATOR	0.18 Kw 3,000 r.p.m		
ELEVATOR CONVEYOR BELT'S REDUCER	i = 30 - 112 B5		
EXTRACTOR CONVEYOR BELT'S REDUCER	i = 25 - 200 B5		
ELEVATOR CONVEYOR BELT	BUCKET CONVEYOUR BELT (380 mm x 110 mm)		
EXTRACTOR CONVEYOR BELT	CONVEYOR BELT (450 mm x 1,300 mm)		

Due to the constant process of improvement at factory, all data are subject to modification without prior notice, being merely illustrative all data in this catalogue.

MADRID: Ctra de Valencia, Km 19,200. 28524 RIVAS VACIAMADRID (MADRID). FAX: +34916701005. e-mail:madrid@mlorenzana.com

LEÓN: Pol. Ind. Villacedré. 24009 VILLACEDRÉ (LEÓN). FAX: +34987849036. e-mail:leon@mlorenzana.com

www.mlorenzana.com +34 902 151 236



REF CAT: 00.PM.00.13.EN.02

BATCHING PLANT



BATCHING PLANT

