

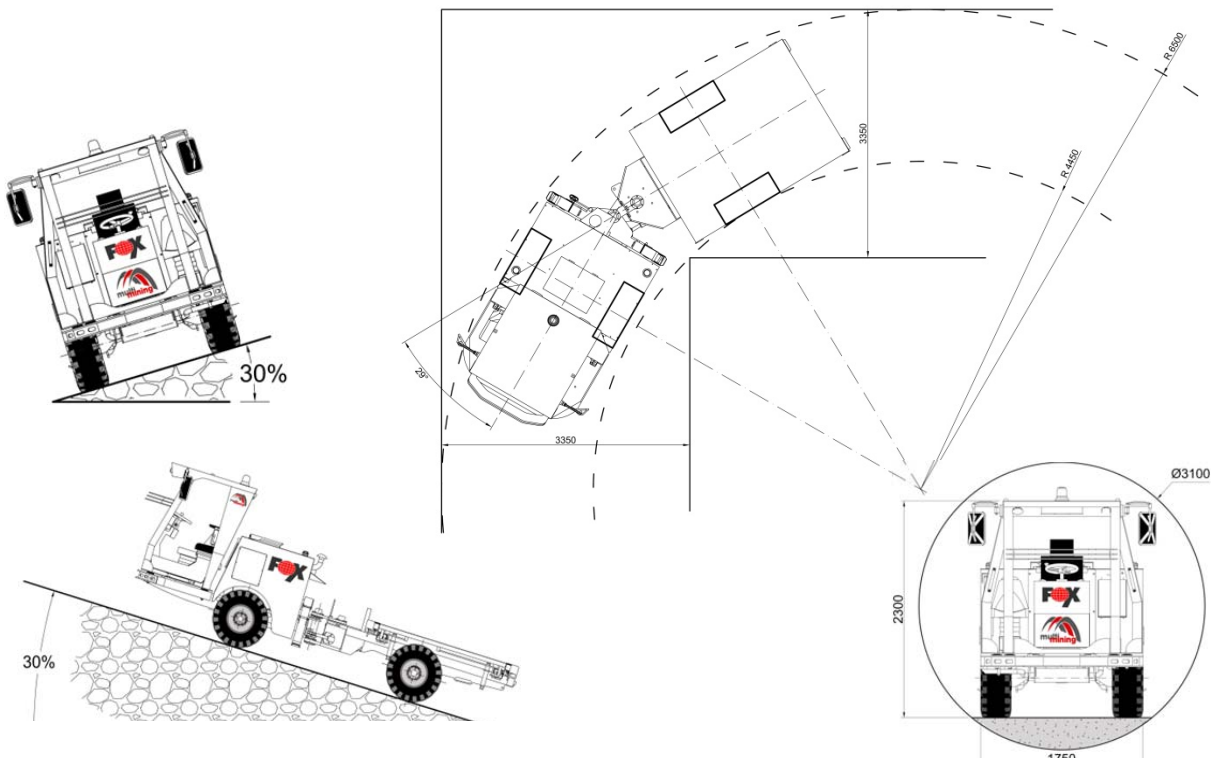



FOX Is the answer to the request of a strong multifunctional vehicle for low-profile tunnels which accomplishes all safety regulations. Its great mobility, small dimensions, working capacity, easy-to-use and the proven reliability of our equipment, give it unique features in the market. Its special configuration, with articulated chassis, its engine and its design, provides the strength and flexibility to work under the most extreme conditions, from extreme cold to tropical temperatures.

The powerful engine allows it to work **without loss of power up to 5,000 MASL** and to overcome slopes up to 30% full load.



FOX is equipped with all the elements to make easy a hard work: **Rotary driving place, quick-coupling interchangeable equipment. A full accessibility to high rotation components**, make its use and maintenance not a loss of time, but, using it properly, the reason for a long-lasting and reliable unit.

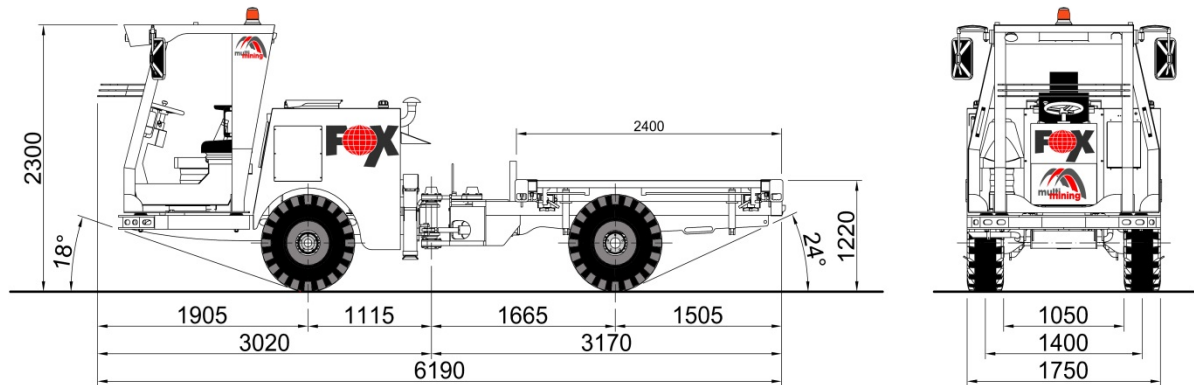

THE ANSWER TO YOUR NEEDS

The equipment is designed to respond to your needs, with the development of the platform that customers demand, from a loading platform, to a personnel carrier, or a machinery-cleaning unit, or welding equipment, or oils and fuel dispenser... tell us what you need and we will provide you with the solution.

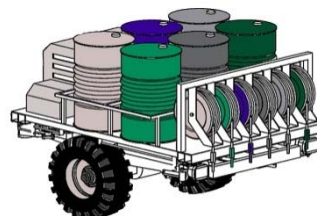
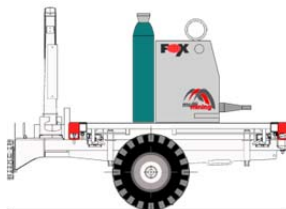

EASY TO TRANSPORT

In this global world, forwarding equipment in a fast and safe way has become a need and an obligatory feature. The unit has been designed for shipping two units in one only container, which can be delivered anywhere in the world.

FOX is working in such different places as Zambia, South Africa, México, Bolivia, Peru... No need of more introductions; It is the answer to your requirements in in this type of equipment for low-profile tunneling and mining.



BRAND		C.O.C.
MODEL		FOX
ENGINE	BRAND	DEUTZ
	MODEL	TD2011L04i
	COOLING	AIR-OIL
	NORMATIVE	TIER III (COM III)
	POWER	(74.5 CV) 54.7 Kw AT 2,600 r.p.m.
	TYPE	TURBO INTERCOOLER
TRANSMISSION	TYPE	HYDROSTATIC
	GEARS	3 GEARS FORWARD AND REVERSE
HYDRAULIC CIRCUITS	SHIFT	HYDROSTATIC WITH HEAT INTERCHANGER
	SERVICES	GEARS PUMP
AXLES		4 MOTOR-WHEELS
CABIN		OPEN
		ROPS - FOPS
DRIVER'S SEAT		ROTATORY 180º
DRIVE		4-WHEEL
STEERING	TYPE	HYDROASSISTED ON CENTRAL JOINT
BRAKES	SERVICE	HYDRAULIC ON REAR MOTOR-WHEELS
	PARKING	NEGATIVE HYDRALIC ACT. ON 4 MOTOR-WHEELS
DIMENSIONS		6,190 mm x 1,750mm x 2,200mm
STEERING RADIOUS	INNER	4,450 mm
	OUTTER	6,500 mm
SPEED		20 KM/H ACCORDING TO SPANISH RULES
MÁXIMUM SLOPE		30%
ELECTRICAL SYSTEM		2 BATTERIES 12V, 110 Ah
TYRES		12.00 - 16,5
WEIGHT		5,500 Kgs
HYDRAULIC OIL TANK		290 L
FUEL TANK		195 L
PLATFORM	TYPE	PLATFORM
	DIMENSIONS	2,400 mm x 1,750 mm
	LOADING CAPACITY	3,500 Kg
CRANE		OPTIONAL
LOADING CAPACITY BY LENGHT	1.33 mt	1,465 Kgs
	2.75 mt	870 Kgs
	3.18 mt	615 Kgs

Due to the constant process of improvement at factory, all data are subject to modification without prior notice, being merely illustrative all data in this catalogue.

MADRID: Ctra de Valencia, Km 19,200. 28524 RIVAS VACIAMADRID (MADRID). FAX: +34916701005. e-mail:madrid@mlorenzana.com

LEÓN: Pol. Ind. Villacedré. 24009 VILLACEDRÉ (LEÓN). FAX: +34987849036. e-mail:leon@mlorenzana.com

www.mlorenzana.com +34 902 151 236



REF CAT: 01.FX.00.13.EN.02