

M. LORENZANA, S.A.

CARRIER OF CONCRETE

MAMUT-2

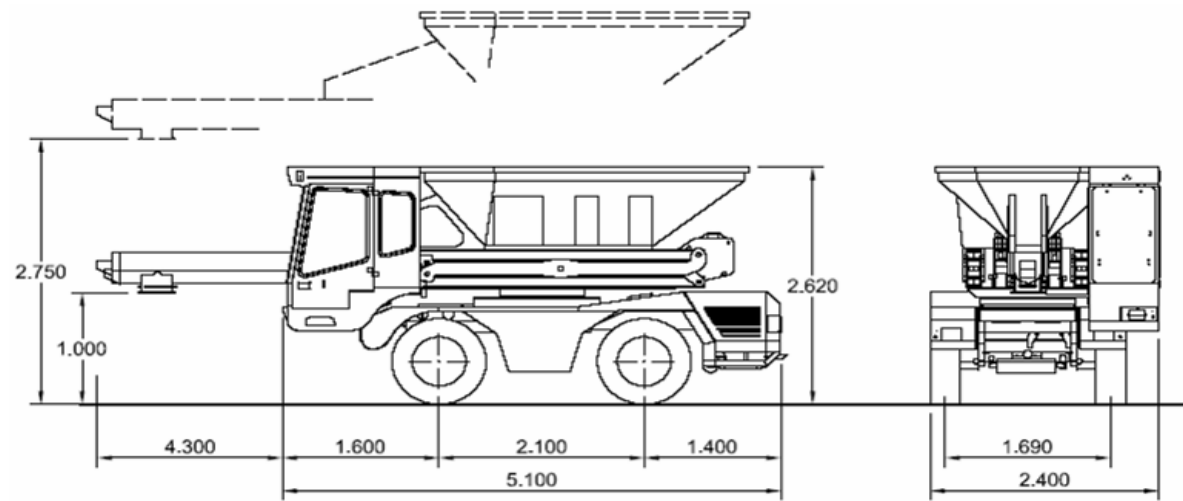

GENERAL SPECIFICATIONS

CHASSIS: Monoblock. Heavy duty type.

ENGINE: Ecological, Deutz make. Four stroke diesel, four cylinders, forced liquid cooling. Maximum power DIN 70 HP to 2.500 r.p.m.

TRANSMISSION: Hydrostatic type. Axial pistons pump of variable displacement. Hydraulic motor at axial pistons of variable displacement. Both with automatic regulation through DA valve. Two speeds gear box in both driving directions.

STEERING: Hydraulic steering operating either on one axle or on both.

CABIN: Front closed cabin with windscreen whippers and regulable seat.

AXLES: Steering type front and rear axle, this last with oscilating assembly. Loading capacity 6.000 kg each. All wheel drive.

BRAKES: - Service: Hydraulic internal shoe type acting on four wheels.
- Parking: Disc type on transmission with hand level control.
Reserved brake at stopped engine.

HIDRAULIC CIRCUITS: Three different circuits with only one tank:
- TRANSMISSION: Hydrostatic circuit cooling through oil-air intercooler.
- HOPPER ROTATION: Gear pump circuit.
- WHOLE WORKING: Gear pump circuit.

HOPPER EQUIPMENT: Total turn of 180° to be able to unload concrete at any point around the machine.

Maximum capacity: 2 m³

Maximum unloading height: 2.750 mm

Minimum unloading height: 1.000 mm

Hydraulic rotation of the conveyor in both senses for unloading, through hydraulic engine driven by gear pump.

SPEED: Progressive from 0 to 20 km/h

STEERING RADIUS: Internal: 1,50 m.
External: 7,50 m.

MAX. SLOPE: Fully loaded: 5 %.

ELECTRICAL EQUIPMENT: 12 V battery and all regular lighting devices and signals for road traffic.

CAPACITIES - Oil tank:.....125 l.
- Fuel tank:105 l.

TYRES: Industrial type 12,5 / 80 - 18.

WEIGHT: 5.800 kg.

NOTICE: If the maching is moving, the hopper must be in its minimal position.



"All data are subject to modifications without prior notice"



M. LORENZANA, S.A.

MADRID: Ctra de Valencia, Km 19,200. 28529 RIVAS VACIAMADRID (MADRID). FAX: +34 916 701 005

LEÓN: Pol. Ind. Villacedré. 24194 VILLACEDRÉ (LEÓN). FAX: +34 987 849 036

VALENCIA: Pol. Ind. El Oliveral. C/C, 12. 46190 RIBARROJA DEL TURIA (VALENCIA). FAX: +34 961 643 073

www.mlorenzana.com TEL: +34 902 151 236

MAMUT-2

